



Overview

The PMC-TS1 receives various Global Navigation Satellite System (GNSS) signals and distributes high-accuracy time via IRIG-B, PPS and NTP/SNTP protocols. It is ideal for accurate time synchronization requirements in Electric Power System applications, such as fault detection, sequence of event timestamping, data acquisition and so on.

Features

- Selectable GNSS (Global Navigation Satellite System) time sources including GPS/Galileo/QZSS
- 2xIRIG-B DC Level Shift signal output with accuracy of <150ns (1 σ)
- Optionally GPS PPS (pulse per second) signal output with accuracy of <150ns (1 σ)
- 1xRS-485 and 1x10/100BaseT Ethernet port for communications
- 1xForm C Mechanical Relay for power outage alarm
- Supporting SNTPv2 via Ethernet network, servicing 400 SNTP requests per second.
- Maintaining accuracy of 55us after 1 hour at constant temperature with standard Temperature Compensated Crystal Oscillator (TCXO) holdover
- Supporting multi-constellation to allow accurate navigation in harsh environments

Terminals Diagram

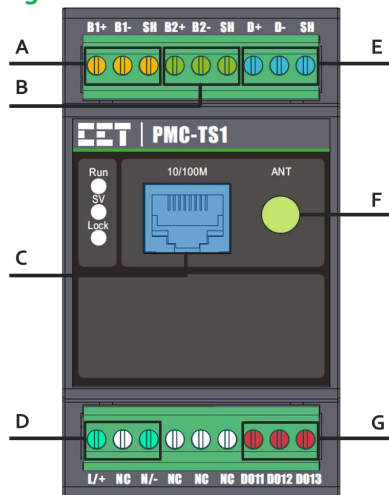

A	IRIG-B Output	E	RS-485 Port
B	IRIG-B/GPS PPS Output	F	GNSS Antenna SMA Female Interface
C	10/100BaseT Ethernet Port	G	Form C Alarm Output
D	Power Supply		

Typical Applications

Various applications where time synchronization is essential for:

- Real-time Data Acquisition
- Real-time Control Process
- Fault Analysis and Location
- Tariff Billing

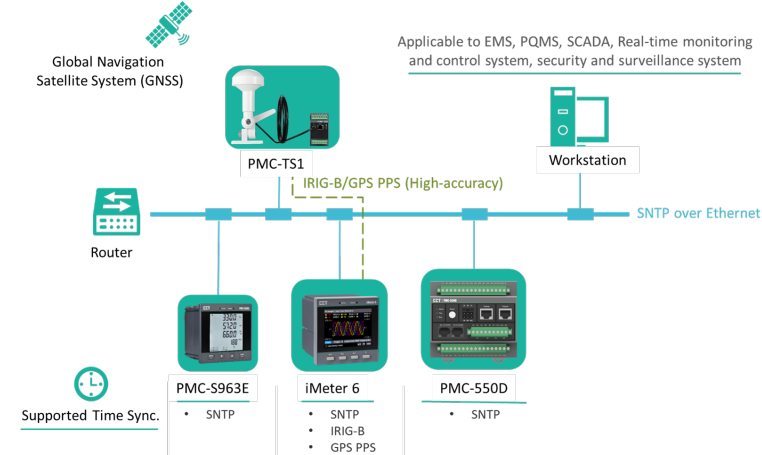

Standards of Compliance

Safety Requirements	
CE LVD 2014/35/EU	EN 61010-1: 2010 + A1: 2019 EN 61010-2-030: 2010
Electrical Safety in Low Voltage Distribution Systems up to 1000Vac and 1500Vdc	IEC 61557-12: 2018 (PMD)
Insulation	IEC 62052-31: 2015
AC Voltage: 3kV @1 min Impulse Voltage: 6kV, 1.2 /50 μ s	
Electromagnetic Compatibility EMC 2014/30/EU (EN 61326: 2013)	
Electrostatic Discharge	EN 61000-4-2: 2009
Radiated Fields	EN 61000-4-3: 2006 + A1: 2008 + A2: 2010
Fast Transients	EN 61000-4-4: 2012
Surges	EN 61000-4-5: 2014 + A1: 2017
Conducted Disturbances	EN 61000-4-6: 2014
Magnetic Fields	EN 61000-4-8: 2010
Voltage Dips and Interruptions	EN 61000-4-11: 2004 + A1: 2017
Ring Waves	EN 61000-4-12: 2017
Mechanical Tests	
Spring Hammer Test	IEC 62052-31: 2015
Vibration Test	IEC 62052-11: 2020
Shock Test	IEC 62052-11: 2020

Technical Specifications

Power Supply (L/+, N/-)	
Standard Burden	95-250VAC/DC \pm 10%, 47-440Hz <4W
IRIG-B Output 1/2 (B1+, B1-, B2+, B2-)	
Accuracy (to UTC)	<150ns (1 σ)
Signal Type	DC Level Shift, Unmodulated
Protocol	IEEE 1344

Designed For Reliability

Manufactured To Last



Optional GPS PPS Output (B2+, B2-)	
Accuracy	<150ns (1σ) to UTC
TCXO	
Time-keeping Accuracy (at constant temperature)	55us in 1 hour and 1ms in 24 hours after disconnecting from Satellite
Reception Capability	GPS L1C/A, Galileo E1 C/A, QZSS L1 C/A
Sensitivity	
Acquisition Period	>-147dBm
Reacquisition Period	>-154dBm
Tracking Period	>-162dBm
Concurrent Reception	Max. 33 tracking channels
Acquisition Time	
Cold Start (First request)	5 minutes
Warm Start (Reconnection)	2 minutes (with saved ephemeris data)
GNSS Antenna (SMA Male Connector)	
IP Protection	IP67
Polarization	RHCP (Right Hand Circular Polarization)
Antenna Gain	> 4dBi (at 90° elev. angle) > -2dBi (at 10° elev. angle)
Output Impedance	50Ω
Preamp Gain	28±3dB (Magnetic Antenna) 35±2dB (Ceramics Antenna)
Preamp Noise Figure	≤1.5dB
VSWR	≤2.0
Supply Voltage	3.5VDC
Power Consumption	20mA max.
SNTP	
Accuracy (to UTC)	0.5-2 ms
Version	SNTP v2
Alarm Output (DO11, DO12, DO13)	
Type	Form C Mechanical Relay
Loading	5A @ 250VAC or 24VDC
Environmental Conditions	
Operating Temp.	-25°C to +70°C
Storage Temp.	-40°C to +85°C
Humidity	5% to 95% non-condensing
Atmospheric pressure	70kPa to 106kPa
Pollution Degree	2
Mechanical Characteristics	
Unit Dimensions	54x97.2x111.8 mm
Shipping Weight	TBD
Shipping Dimensions	TBD
Mounting	DIN-Rail Mounting
IP Rating	IP51

Dimensions and Installations

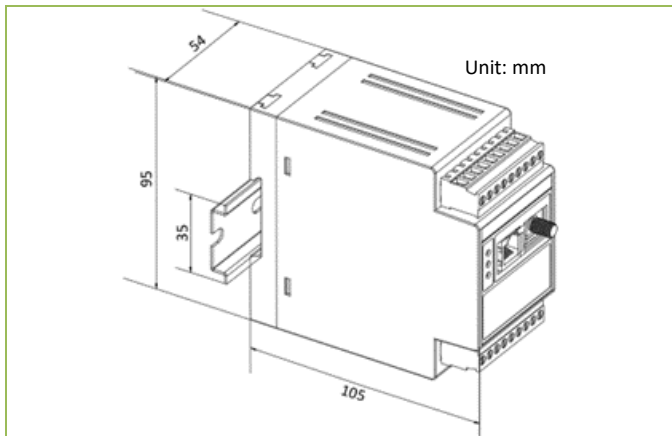

Ordering Guide

Product Code		Description
PMC-TS1 Time Server		
Signal Output		
2	2	2xIRIG-B Output (DCLS) or 1xIRIG-B (DCLS) + 1xGPS PPS Output
Power Supply		
2	2	95-250VAC/DC ± 10%, 47-440Hz
System Frequency		
5	5	50Hz/60Hz
Communications		
E	E	1xRS-485 + 1x10/100BaseT Ethernet Port
Time Keeping Accuracy		
A	A	< 55us in 1 hour after disconnecting from Satellite
PMC-TS1	- 2 2 5 E A	PMC-TS1-225EA (Standard Model)

*It is highly recommended to select a Multi-GNSS Antenna from the "Antenna" table to match the PMC-TS1 for a better performance. The selectable Antennas can receive signals from GPS/Galileo/QZSS constellation with a high gain at over 28dB. If the user plans to use other GNSS Antennas, please contact CET for detailed Antenna Requirements.

Antenna		Specification/Description
Model #	STA-67301	Ceramics Antenna with 2m Cable, SMA Male Connector and Mounting Bracket
Model #	STA-67302	Ceramics Antenna with 10m Cable, SMA Male Connector and Mounting Bracket
Model #	STA-67303	Ceramics Antenna with 20m Cable, SMA Male Connector and Mounting Bracket
Model #	STA-67304	Ceramics Antenna with 50m Cable, SMA Male Connector and Mounting Bracket
Model #	STA-67305	Ceramics Antenna with 80m Cable, SMA Male Connector and Mounting Bracket
Model #	STA-67306	Ceramics Antenna with 100m Cable, SMA Male Connector and Mounting Bracket
Model #	DD100005996	Magnetic Antenna with 3m Cable, SMA Male Connector and 3M Sticker
Model #	DD6002357	Magnetic Antenna with 10m Cable, SMA Male Connector and 3M Sticker

Antennas' Appearance
Ceramics Antenna
(with Mounting Bracket)



Magnetic Antenna
(with 10m Cable, SMA Male Connector and 3M Sticker)



CET Electric Technology Inc.

E: sales@cet-global.com

W: www.cet-global.com

Your Local Representative



Revision Date: April 1, 2024

Designed For Reliability

Manufactured To Last